



技术咨询和询价：010-68940148

Bmic

Leak Monitoring Device

Bmic is an easy to use electronic leak monitoring tool, ideal for general water leak detection operations.

Cost-effective and simple to use, Bmic is intended to minimise disruption and support leakage technicians to reduce repair times.

Bmic is lightweight, allowing for simple one-handed operation, while the compact control unit is designed to attach comfortably to a belt. This allows the user to hold the microphone while still being able to easily operate the control unit.



Key Features and Benefits

- **Easy to use:** lightweight and one-handed operation
- **Surface sound:** elephants foot microphone for surface sounding (optional)
- **Flexible:** optional hand-probe for direct contact sounding on pipes and fittings
- **Excellent acoustic performance:** microphone allows for superior sound quality due to the wind-proof housing
- **Hands-free:** belt-mounted control unit
- **Robust:** field-proof design
- **User-friendly:** minimal button operation for ease of use
- **Rechargeable:** overnight battery charge

Applications

Bmic is supplied with a hand probe which is designed to make direct contact on accessible pipes and fittings. It is also compatible with an attachable tripod, which can be inserted into soft ground at the pinpointing stage.

The system can also be supplied with an optional an "elephant's foot" microphone for surface sounding. The microphone allows for superior sound quality due to the wind-proof housing almost eliminating background noise.

MONITORING ASSETS, DELIVERING DATA, BRINGING CONTROL

www.hwmglobal.com

Bmic

Leak Monitoring Device

Features

Construction	Piezoelectric high sensitivity sensor mounted in PC-ABS (polycarbonate) housing. Single headphone/charger input socket with automatic sensing of device connected
Acoustically Shielded "Elephants Foot" Microphone (optional)	High sensitivity piezo-electric sensor mounted in wind-proof, nitrile rubber housing. Low noise. 1.5m cable (detachable). Weight: 2.9kg
Hand Probe Attachment	The hand probe is supplied with a tripod foot and two stainless steel probe rods for sounding in soft ground plus magnetic contact for better coupling to fittings. Each probe rod is 400mm in length
Connectors	Amphenol military specification connectors for microphone and headphone
Charging	Universal 110-240V AC charger with 12V DC output. Car cigarette lighter adapter with 12V DC output (optional accessory) 4-pin Amphenol connectors to control unit Charge time: Overnight charge
LED	Green = normal operation Red = low battery power
Headphones	Studio quality headphones are supplied as standard. Aviation Quality headphones are available as an option
Carriage	Supplied in Hard Carry Case

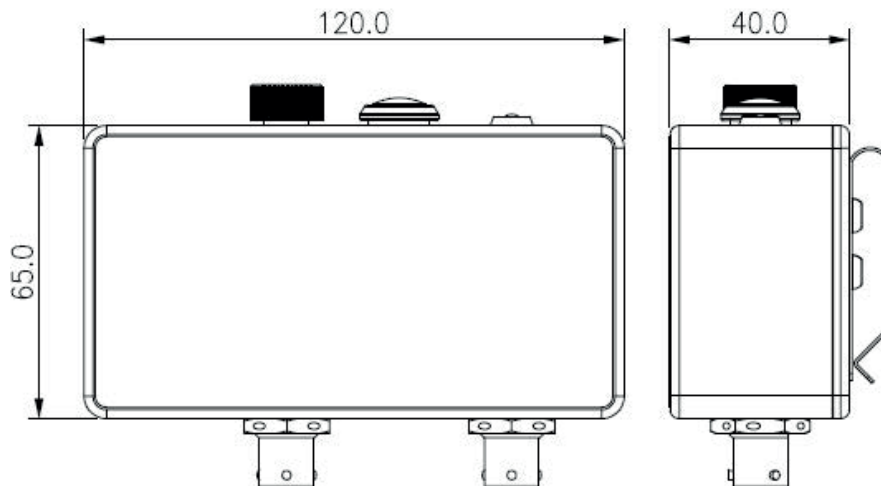

All images, text and designs are protected by international and UK copyright law and remain the property of HWM. It is against the law to copy or use any of the content from HWM website or literature without the written consent of HWM. HWM Ltd. reserve the right to vary the specification.



HWM Water Limited

Ty Coch House
Llantarnam Park Way
Cwmbran
NP44 3AW
United Kingdom

Tel: +44 (0) 1633 489 479
Fax: +44 (0) 1633 877 857
Email: sales@hwm-water.com
Web: www.hwmglobal.com

MONITORING ASSETS, DELIVERING DATA, BRINGING CONTROL